

GAS PRESSURE REGULATORS CATALOG

4th Edition

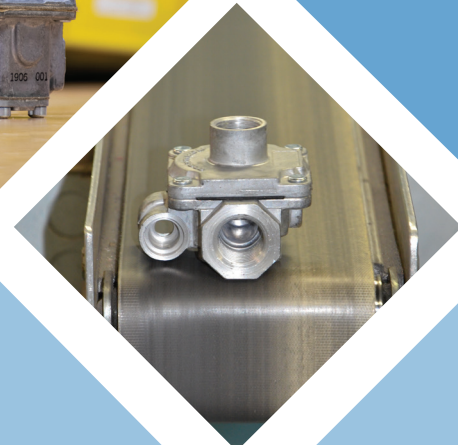

▲ WARNING

Service and installation must be performed by a trained/experienced service technician.

All products used with combustible gas **must** be installed and used **strictly** in accordance with the instructions of the Original Equipment Manufacturer (OEM) and with all applicable government codes and regulations, e.g. plumbing, mechanical, and electrical codes and practices. Maxitrol products should be installed and operated in accordance with Maxitrol Safety Warning Instructions.

Maxitrol Company is NOT responsible for any errors or omissions in reliance by anyone of any information set forth in this catalog without additional reference to local requirements and applicable ordinances or codes.

Other worldwide approvals and certifications available upon inquiry.



325-L SERIES

Lever Acting Design for 2 psi Piping Systems

Maxitrol's 325-L series line pressure regulators are for 2 psi piping systems. 325 series regulators are for use on residential, commercial, and industrial applications.

The 325 series features a high leverage linkage assembly to deliver positive dead-end lockup. The regulators are capable of precise regulating control from full flow down to pilot flow.



325-3L

Specifications

Pipe Sizes 3/8" to 2" threaded connections with NPT or ISO7-1 threads.
Optional 1/8" NPT outlet pressure taps on 325-7, 325-9, and 325-11.

Housing Material 325-3L, 325-5L, 325-7AL, 325-9L, 325-11L: aluminum.

Mounting All models with the exception of the 325-11L are suitable for multi-positional mounting. The 325-11L is to be mounted in a horizontal upright position only. If a **vLimiter®** or **vProtector®** is installed, mount in an upright position only.

NOTE: All Maxitrol gas pressure regulators should be installed and operated in accordance with Maxitrol Safety Warning Instructions (see GPR_CSA_2PSI_MI_EN.FR).

Certifications 325-3L, 325-5L, 325-7AL, 325-9L, 325-11L: ANSI Z21.80/CSA 6.22 Line Pressure Regulators.

Gas Types Suitable for natural, manufactured, mixed gases, liquefied petroleum gases, and LP gas-air mixtures.

Rated Inlet Pressure CSA Certified: 2 psi (13.8 kPa)

Maxitrol Tested 10 psi (69 kPa)

Emergency Exposure Limits 65 psi (450 kPa) (inlet side only)

Maximum Individual Load Largest single appliance served by the regulator: 325-3L: 140,000 Btu/h; 325-5L: 425,000 Btu/h; 325-7AL: 1,250,000 Btu/h; 325-9L: 2,250,000 Btu/h; 325-11L: 4,450,000 Btu/h

Capacity Total load of multiple appliance combined
325-3L (3/8", 1/2"): 250,000 Btu/h;
325-5L (1/2"): 500,000 Btu/h; 325-5L (3/4", 1"): 600,000 Btu/h;
325-7AL (1 1/4", 1 1/2"): 1,250,000 Btu/h; 325-9L (1 1/2", 2"): 2,250,000 Btu/h; 325-11L (2, 2 1/2", 3"): 4,450,000 Btu/h

NOTE: Capacities are used to determine the maximum multiple appliance load. The largest single appliance served by the regulator should not exceed the maximum individual load specified above.

Ambient Temperature Ranges -40 to 205°F (-40 to 96°C)

Minimum Regulation Suitable for pilot flow applications. (P) (Circle P) (0.15 CFH NG).

Imblue Technology™ 325-3L, 325-5L, 325-7AL, 325-9L models may be ordered with Imblue Technology™. ImblueTechnology™ increases corrosion resistance and provides extra protection against the elements for regulators used in outdoor applications. Add suffix letter "B" to model number when ordering.



Capacities

Capacities expressed in CFH (m³/h) @ 0.64 sp gr gas

| Model | Pipe Size | Outlet Pressure Set Point | Operating Inlet Pressure | | | | |
|---------|---------------------------------------|---------------------------|--------------------------|-------------------|-----------------|--------------------|------------------|
| | | | .5 psi (3.4 kPa) | .75 psi (5.2 kPa) | 1 psi (6.9 kPa) | 1.5 psi (10.3 kPa) | 2 psi (13.8 kPa) |
| 325-3L | 3/8" x 3/8" 1/2" x 1/2" | 7.0" w.c. (1.7 kPa) | 145 (4.1) | 200 (5.7) | 250 (7.1) | 250 (7.1) | 250 (7.1) |
| | | 10.0" w.c. (2.5 kPa) | 110 (3.1) | 180 (5.1) | 230 (6.5) | 250 (7.1) | 250 (7.1) |
| 325-5L | 1/2" x 1/2" | 7.0" w.c. (1.7 kPa) | 360 (10.2) | 485 (13.7) | 500 (14.2) | 500 (14.2) | 500 (14.2) |
| | | 10.0" w.c. (2.5 kPa) | 275 (7.8) | 475 (13.5) | 500 (14.2) | 500 (14.2) | 500 (14.2) |
| 325-5L | 3/4" x 3/4" 1" x 1" | 7.0" w.c. (1.7 kPa) | 370 (10.5) | 520 (14.7) | 600 (17.0) | 600 (17.0) | 600 (17.0) |
| | | 10.0" w.c. (2.5 kPa) | 275 (7.8) | 450 (12.7) | 570 (16.1) | 600 (17.0) | 600 (17.0) |
| 325-7AL | 1 1/4" x 1 1/4" 1 1/2" x 1 1/2" | 7.0" w.c. (1.7 kPa) | 750 (21.2) | 1000 (28.3) | 1250 (35.4) | 1250 (35.4) | 1250 (35.4) |
| | | 10.0" w.c. (2.5 kPa) | 525 (14.9) | 900 (25.5) | 1125 (31.9) | 1250 (35.4) | 1250 (35.4) |
| 325-9L | 1 1/2" x 1 1/2" 2" x 2" | 7.0" w.c. (1.7 kPa) | 1390 (39.4) | 2080 (58.9) | 2250 (63.7) | 2250 (63.7) | 2250 (63.7) |
| | | 10.0" w.c. (2.5 kPa) | 1050 (29.7) | 1660 (47.0) | 2090 (59.2) | 2250 (63.7) | 2250 (63.7) |
| 325-11L | 2" x 2" 2 1/2" x 2 1/2" 3" x 3" | 7.0" w.c. (1.7 kPa) | 3000 (85.0) | 3900 (110.4) | 4500 (127.4) | 4500 (127.4) | 4500 (127.4) |
| | | 10.0" w.c. (2.5 kPa) | 1890 (53.5) | 2770 (78.4) | 3600 (101.9) | 4500 (127.4) | 4500 (127.4) |

NOTE: See pages 58-59 for Regulator Sizing Requirements and Examples.

Pressure Drop: expressed in CFH (m³/h) @ 0.64 sp gr gas

| Model Number | 7.0" w.c. (1.7 kPa) | .5 psi (3.4 kPa) | .75 psi (5 kPa) |
|--------------|---------------------|------------------|-----------------|
| 325-3L | 145 (4.0) | 204 (5.8) | 250 (7.0) |
| 325-5L | 400 (11.3) | 550 (15.6) | 670 (19.0) |
| 325-7AL | 815 (23.1) | 1149 (32.5) | 1405 (39.8) |
| 325-9L | 1360 (38.5) | 2113 (59.8) | 2557 (72.4) |
| 325-11L | 3000 (85.0) | 4220 (119.5) | 5170 (146.4) |

Spring Selection

Outlet Pressure Range (all models)

Certified Spring 7" to 11" w.c. (1.7 to 2.7 kPa)

NOTE: See to pages 56-57 for complete Spring Selection Chart.

325-L SERIES

Lever Acting Design for 2 psi Piping Systems

Dimensions

| Model | Pipe Size | Vent Connection | Swing Radius | Dimensions | | |
|---------|----------------|-----------------|-------------------|-------------------|-------------------|-------------------|
| | | | | A | B | C |
| 325-3L | 3/8", 1/2" | 1/8" NPT | 3" (76 mm) | 3.5" (89 mm) | 4.2" (108 mm) | 3.9" (98 mm) |
| 325-5L | 1/2", 3/4", 1" | 3/8" NPT | 4.9" (124 mm) | 5.3" (133 mm) | 5.9" (149 mm) | 5.4" (138 mm) |
| 325-7AL | 1 1/4", 1 1/2" | 1/2" NPT | 6.1" (156 mm) | 7.3" (184 mm) | 8" (203 mm) | 7" (178 mm) |
| 325-9L | 1 1/2", 2" | 1/2" NPT | 7.8" (198 mm) | 9.4" (239 mm) | 10.8" (274 mm) | 9.1" (231 mm) |
| 325-11L | 2", 2 1/2", 3" | 3/4" NPT | 11.0" (279 mm) | 13.1" (333 mm) | 16.1" (409 mm) | 13.5" (343 mm) |

NOTE: Dimensions are maximums and to be used only as an aid in designing clearance for the valve.
Actual production dimensions may vary somewhat from those shown.

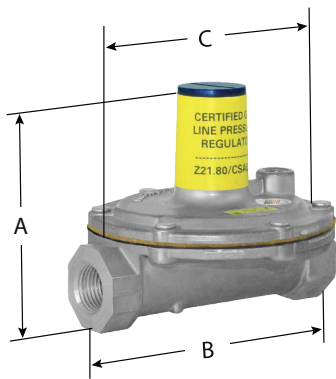

325-3L

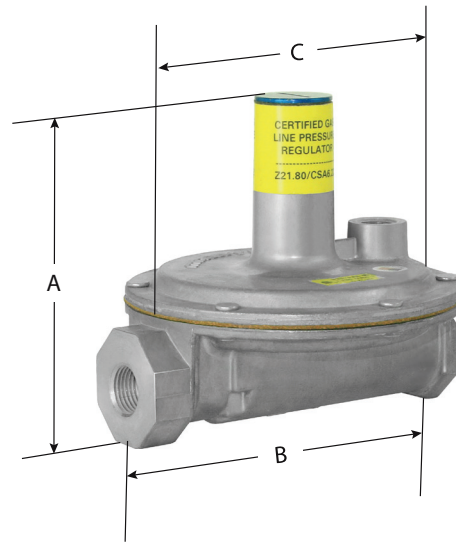

325-5L

LINE REGULATORS

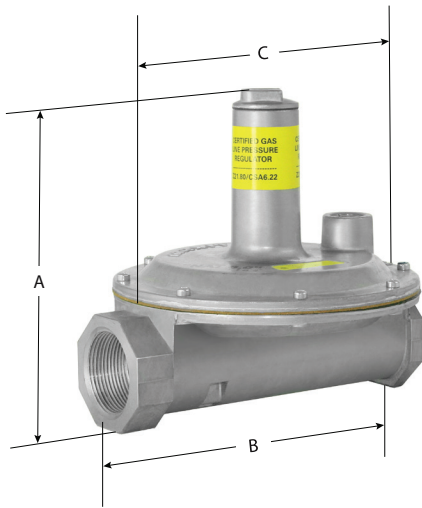

325-7AL

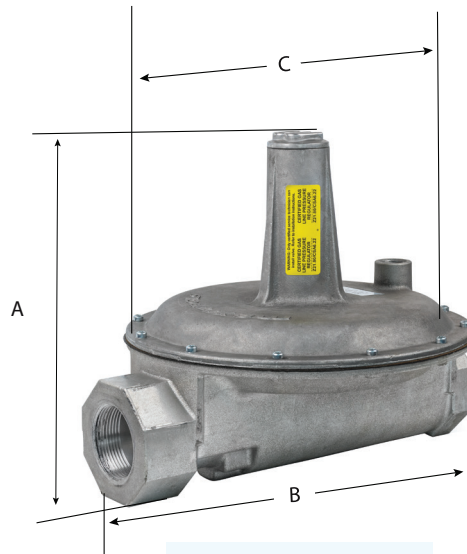

325-11L

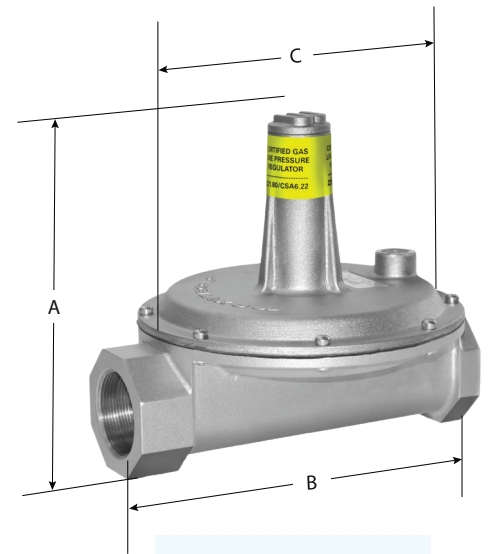

325-9L

Lever Acting Design

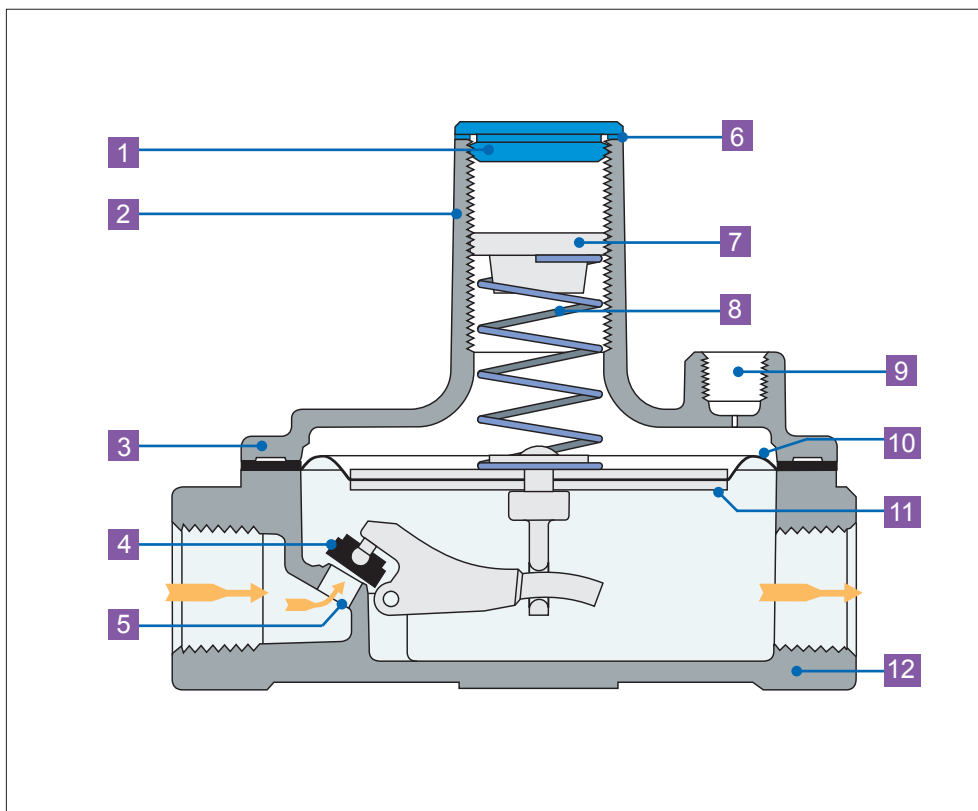

- 1 Seal Cap
- 2 Stack
- 3 Top Housing
- 4 Rubber Valve
- 5 Valve Seat
- 6 Seal Cap Gasket
- 7 Adjusting Screw
- 8 Spring
- 9 Vent Connection
- 10 Diaphragm
- 11 Diaphragm Plates
- 12 Bottom Housing

NOTE: Diagrams are graphical representations only and may differ from actual product.

SIZING A REGULATOR

See www.maxitrol.com for our Regulator Sizing Program. Please contact Maxitrol directly for more information on sizing a regulator.

System Requirements

When sizing a regulator the following must be known:

- Gas Type
- Available Inlet Pressure
- Desired Outlet Pressure
- Zero Governor Application (indicated by model number ending in "Z")
- Will the regulator control main burner and pilot load OR main burner only?
- Required minimum and maximum flow rate in cfh or m³/h or Btu/h
- Pipe Size

In most cases, the manifold pipe size has already been selected on the basis of good engineering practice, and the regulator pipe size should conform to this size.

The capacity of any regulator is not an absolute value but will vary with the application depending on the prevailing differential pressure.

▲ WARNING

Service and installation must be performed by a trained/experienced service technician.

All products used with combustible gas must be installed and used strictly in accordance with the instructions of the Original Equipment Manufacturer (OEM) and with all applicable government codes and regulations, e.g. plumbing, mechanical, and electrical codes and practices. These instructions do NOT supersede OEM's installation or operating instructions.

All Maxitrol products should be installed and operated in accordance with Maxitrol Safety Warning Instructions.

HOW TO CALCULATE PRESSURE DROP AT VARIOUS FLOW RATES FROM CAPACITY CHART

LP Applications - When using natural gas pressure drop chart to determine LP pressure drop in terms of Btu/h, multiply NAT Btu/h by 1.61; in terms of CFH multiply NAT CFH by 0.645.

$$\text{Formula: } P_2 = P_1 \times (Q_2/Q_1)^2$$

P₂ = Pressure drop at desired flow rate

P₁ = Known pressure drop

Q₂ = Desired flow rate

Q₁ = Known flow rate

A. Check Capacity Chart, insuring regulator has ample range of regulation and individual load capacities (for use with pilot) for the application.

B. Know the minimum encountered inlet pressure. MINIMUM INLET PRESSURE MINUS "P₂" MUST BE GREATER THAN DESIRED OUTLET PRESSURE. Solve for "P₂" using the formula above. (See examples on page 59.)

Sizing Examples

RUBBER SEAT POPPETS

For main burner and pilot load applications.

Example: To select an RV type regulator:

- Known: Single 150,000 Btu/h main burner; pipe size 1/2"; inlet pressure 7" w.c.; outlet pressure 4" w.c.
- Solution: The RV48 (1/2") has a maximum capacity of 230,000 Btu/h and a maximum individual load of 160,000 Btu/h. The pressure drop at a flow rate of 150,000 Btu/h is 0.4" w.c., well below the available differential of 3" w.c. The RV48 (without "L" fixed orifice) is the correct regulator to use for the application.

STRAIGHT-THRU-FLOW (S-T-F)

For main burner only applications not requiring a lockup type regulator. When sizing the S-T-F series, it is recommended that pressure drop not exceed 1/2 of available differential pressure.

Example: To select an RV type regulator:

- Known: Flow rate 2,000,000 Btu/h; pipe size 1 1/4"; inlet pressure 9" w.c.; outlet pressure 5" w.c.
- Solution: The RV81(1 1/4") has a maximum capacity of 2,500,000 Btu/h. The pressure drop at a flow of 2,000,000 Btu/h is 0.66" w.c. The RV81 (1 1/4") is the correct regulator to use with this application. The pressure drop of the RV61 (1 1/4") at a flow rate of 2,000,000 Btu/h is 2.64" w.c. This is within the available differential but exceeds the recommended 50% maximum.

LEVER ACTING

For main burner and pilot load application requiring positive dead-end lockup (see Definitions page 63).

Example: To select a 325 series regulator:

- Known: Single 145,000 Btu/h burner; pipe size 1/2"; inlet pressure 2 psi; outlet pressure 7" w.c.
- Solution: The 325-3's pressure drop at a flow rate of 145,000 Btu/h is 7" w.c., well below the available differential of 1 3/4 psi. However, the Maximum Individual Load for the 325-3 is only 100,000 Btu/h. The 325-5 (1/2") is the correct regulator to use with this application.

BALANCED VALVE

For main burner and pilot load application requiring a lockup type regulator or zero governor usage (see Definitions page 63).

Example: To select a 210 or R/RS series regulator:

- Known: Desired flow rate 6,000,000 Btu/h; pipe size 1 1/2"; inlet pressure 1 psi; outlet pressure 9" w.c.
- Solution: The 210E (1 1/2") has a maximum capacity of 10,000,000 Btu/h. The 210D (1 1/2") has a capacity of 6,000,000 Btu/h. Therefore, the 210E (1 1/2") will give you the desired outlet pressure of 9" w.c. and is the correct regulator to use for the application.

MAXITROL®

Exclusive Distributor North America
for Mertik Maxitrol

Maxitrol Company, Inc.
23555 Telegraph Rd., PO Box 2230
Southfield, MI 48037-2230
USA
Tel: +1 248-356-1400
Fax: +1 248-356-0829
www.maxitrol.com

