

GAS PRESSURE REGULATORS CATALOG

4th Edition

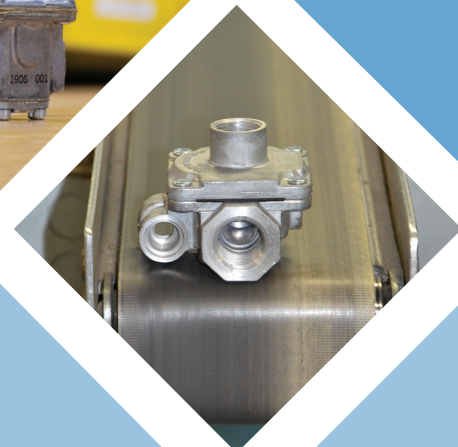

▲ WARNING

Service and installation must be performed by a trained/experienced service technician.

All products used with combustible gas **must** be installed and used **strictly** in accordance with the instructions of the Original Equipment Manufacturer (OEM) and with all applicable government codes and regulations, e.g. plumbing, mechanical, and electrical codes and practices. Maxitrol products should be installed and operated in accordance with Maxitrol Safety Warning Instructions.

Maxitrol Company is NOT responsible for any errors or omissions in reliance by anyone of any information set forth in this catalog without additional reference to local requirements and applicable ordinances or codes.

Other worldwide approvals and certifications available upon inquiry.



325-L SERIES

Lever Acting Design with OPDs
for 5 psi Piping Systems

Maxitrol's 325-L series line pressure regulators with OPDs are for use on piping systems up to 5 psi. The regulator reduces pounds pressure to a level within the appliance or equipment's operating supply range. The line regulator is located upstream of equipment already fitted with an appliance regulator.



Specifications

Pipe Sizes 3/8" thru 2" threaded connections with NPT or ISO7-1 threads.

Housing Material All models: aluminum.

Mounting All models with the exception of 325-7AL210D, 325-9L210E, and 325-11L210G are suitable for multi-positional mounting. 325-7AL210D, 325-9L210E, and 325-11L210G are to be mounted in a horizontal upright position only. If a **vLimiter**[®] or **vProtector**[®] is installed, mount in an upright position only.

NOTE: Line pressure regulators with separate overpressure protection devices are factory preassembled and supplied to the field as a unit. All Maxitrol gas pressure regulators should be installed and operated in accordance with Maxitrol Safety Warning Instructions (see LPROPD_MI_EN.FR).

Certifications All models: ANSI Z21.80/CSA 6.22 Line Pressure Regulators

Gas Types Suitable for natural, manufactured, mixed gases, liquefied petroleum gases, and LP gas-air mixtures.

Rated Inlet Pressure CSA Certified: 5 psi (34.5 kPa)

Maxitrol Tested 10 psi (69 kPa)

With 12A09, 12A39, or 12A49 vLimiter[®] Installed
Natural: 5 psi (34.5 kPa); LP: 2 psi (13.8 kPa)

Emergency Exposure Limits 65 psi (450 kPa) (inlet side only)

Maximum Individual Load/ Capacity

325-3L47 (3/8", 1/2") (w/OPD 47 attached).....	125,000 Btu/h
325-3L48 (1/2") (w/OPD 48 attached).....	200,000 Btu/h
325-5L48 (1/2") (w/OPD 48 attached).....	235,000 Btu/h
325-5L48 (3/4") (w/OPD 48 attached).....	320,000 Btu/h
325-5L600 (3/4") (w/OPD 600 attached).....	425,000 Btu/h
325-5L600 (1") (w/OPD 600 attached).....	465,000 Btu/h
325-7AL210D (1 1/4", 1 1/2") (w/OPD 210D attached).....	1,250,000 Btu/h
325-9L210E (1 1/2", 2") (w/OPD210E attached).....	2,250,000 Btu/h
325-11L210G (2", 2 1/2", 3") (w/OPD 210G attached).....	4,450,000 Btu/h

Ambient Temperature Ranges -40 to 205°F (-40 to 96°C)

Minimum Regulation Suitable for pilot flow applications. **(P)** (Circle P) (0.15 CFH NG).



Capacities

Capacities expressed in CFH (m³/h) @ 0.64 sp gr gas

Model Number	Pipe Size	Outlet Pressure Set Point	Operating Inlet Pressure			
			1/2 psi (3.4 kPa)	3/4 psi (5.2 kPa)	1 psi (6.9 kPa)	5 psi (34.5 kPa)
325-3L47	3/8" x 3/8"	7" w.c.	125 (3.5)	125 (3.5)	125 (3.5)	125 (3.5)
		10" w.c.	100 (2.8)	125 (3.5)	125 (3.5)	125 (3.5)
325-3L47	1/2" x 1/2"	7" w.c.	125 (3.5)	125 (3.5)	125 (3.5)	125 (3.5)
		10" w.c.	105 (2.9)	125 (3.5)	125 (3.5)	125 (3.5)
325-3L48	1/2" x 1/2"	7" w.c.	160 (4.5)	200 (5.6)	200 (5.6)	200 (5.6)
		10" w.c.	120 (3.4)	200 (5.6)	200 (5.6)	200 (5.6)
325-5L48	1/2" x 1/2"	7" w.c.	235 (6.6)	235 (6.6)	235 (6.6)	235 (6.6)
		10" w.c.	235 (6.6)	235 (6.6)	235 (6.6)	235 (6.6)
325-5L48	3/4" x 3/4"	7" w.c.	320 (9.0)	320 (9.0)	320 (9.0)	320 (9.0)
		10" w.c.	245 (6.9)	320 (9.0)	320 (9.0)	320 (9.0)
325-5L600	3/4" x 3/4"	7" w.c.	345 (9.6)	425 (11.9)	425 (11.9)	425 (11.9)
		10" w.c.	260 (7.3)	425 (11.9)	425 (11.9)	425 (11.9)
325-5L600	1" x 1"	7" w.c.	375 (10.5)	465 (13.0)	465 (13.0)	465 (13.0)
		10" w.c.	285 (8.0)	465 (13.0)	465 (13.0)	465 (13.0)
325-7AL210D	1 1/4" x 1 1/4"	7" w.c.	815 (22.8)	1120 (31.4)	1250 (35.4)	1250 (35.4)
		10" w.c.	580 (16.2)	900 (25.2)	1100 (30.8)	1250 (35.4)
325-7AL210D	1 1/2" x 1 1/2"	7" w.c.	815 (22.8)	1120 (31.4)	1250 (35.4)	1250 (35.4)
		10" w.c.	580 (16.2)	900 (25.2)	1100 (30.8)	1250 (35.4)
325-9L210E	1 1/2" x 1 1/2"	7" w.c.	1380 (38.6)	2000 (56.0)	2250 (63.0)	2250 (63.0)
		10" w.c.	890 (24.9)	1750 (49.0)	2100 (58.8)	2250 (63.0)
325-9L210E	2" x 2"	7" w.c.	1380 (38.6)	2000 (56.0)	2250 (63.0)	2250 (63.0)
		10" w.c.	890 (24.9)	1750 (49.0)	2100 (58.8)	2250 (63.0)
325-11L210G	2" x 2" 2 1/2" x 2 1/2" 3" x 3"	7" w.c.	3000 (85.0)	3900 (110.4)	4500 (127.4)	4500 (127.4)
		10" w.c.	1890 (53.5)	2770 (78.4)	3600 (101.9)	4500 (127.4)

NOTE: See pages 58-59 for Regulator Sizing Requirements and Examples.

Imblue Technology™: All models may be ordered with Imblue Technology™. Imblue Technology™ increases corrosion resistance and provides extra protection against the elements for regulators used in outdoor applications. Add suffix letter "B" to model number when ordering.

325-L SERIES

Lever Acting Design with OPDs
for 5 psi Piping Systems

Pressure Drop

Pressure Drop expressed in CFH (m³/h) @ 0.64 sp gr gas

Model Number	Pipe Size	Pressure Drop		
		7" w.c. (1.7 kPa)	1/2 psi (3.4 kPa)	3/4 psi (5.2 kPa)
325-3L47	3/8" x 3/8"	130 (3.6)	185 (5.2)	225 (6.3)
325-3L47	1/2" x 1/2"	135 (3.8)	195 (5.4)	235 (6.6)
325-3L48	1/2" x 1/2"	160 (4.5)	225 (6.3)	275 (7.7)
325-5L48	1/2" x 1/2"	315 (8.8)	450 (12.6)	545 (15.4)
325-5L48	3/4" x 3/4"	325 (9.1)	465 (13.0)	565 (16.0)
325-5L600	3/4" x 3/4"	345 (9.6)	490 (13.7)	595 (16.8)
325-5L600	1" x 1"	375 (10.5)	535 (15.0)	650 (18.4)
325-7AL210D	1 1/4" x 1 1/4"	800 (22.7)	1095 (31.0)	1385 (39.2)
325-7AL210D	1 1/2" x 1 1/2"	800 (22.7)	1095 (31.0)	1385 (39.2)
325-9L210E	1 1/2" x 1 1/2"	1360 (38.5)	2113 (59.8)	2557 (72.4)
325-9L210E	2" x 2"	1360 (38.5)	2113 (59.8)	2557 (72.4)
325-11L210E	2" x 2" 2 1/2" x 2 1/2" 3" x 3"	2890 (81.8)	4100 (116.1)	5000 (141.6)

NOTE: See pages 58-59 for Regulator Sizing Requirements and Examples.

Spring Range Selection

Outlet Pressure Range (all models)

Certified Spring 7" to 11" w.c. (1.7 to 2.7 kPa)

NOTE: Please refer to pages 56-57 for complete Spring Selection Chart.

Lever Acting Design With OPD

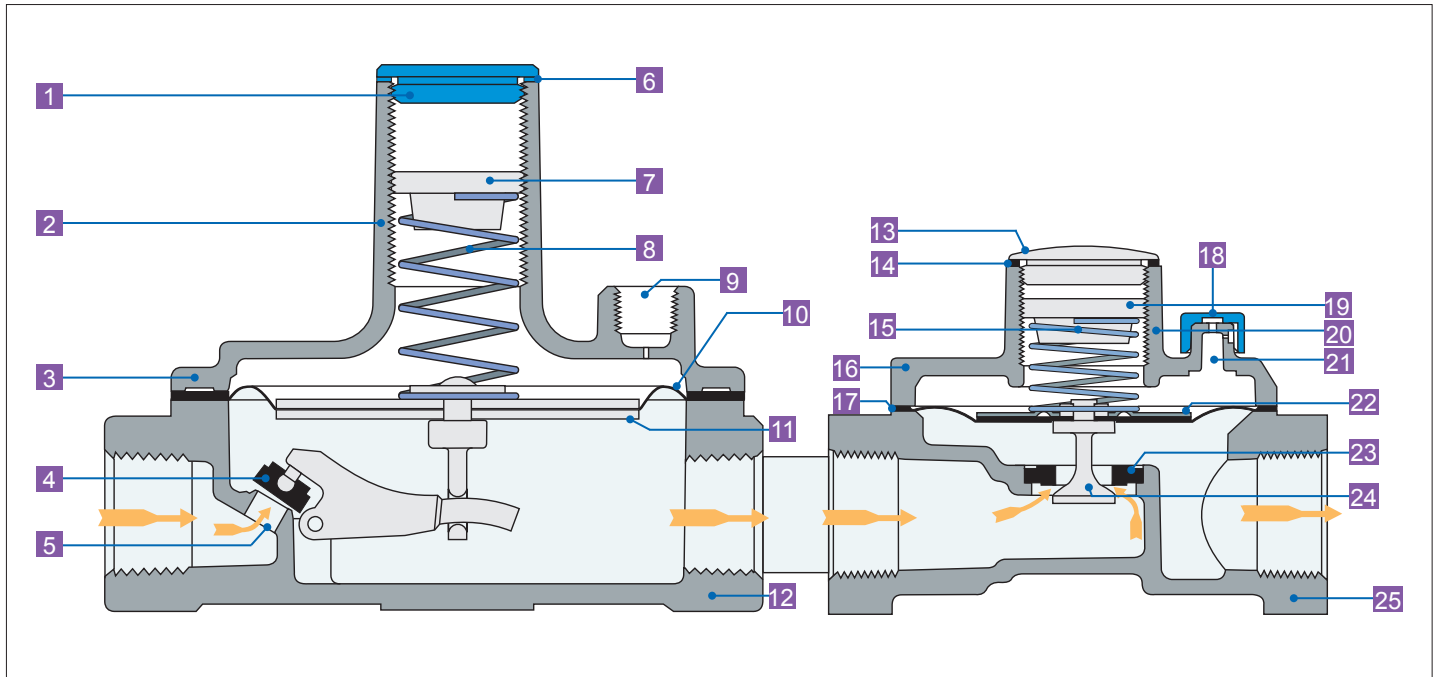

NOTE: Diagrams are graphical representations only and may differ from actual product.

1	Seal Cap	8	Spring	15	Spring	22	Diaphragm Plate
2	Stack	9	Vent Connection	16	Top Housing	23	Rubber Seat
3	Top Housing	10	Diaphragm	17	Diaphragm	24	Stem & Valve
4	Rubber Valve	11	Diaphragm Plates	18	Dust Cap	25	Bottom Housing
5	Valve Seat	12	Bottom Housing	19	Adjusting Screw		
6	Seal Cap Gasket	13	Seal Cap	20	Stack		
7	Adjusting Screw	14	Seal Cap Gasket	21	Vent		

325-L SERIES

Lever Acting Design with OPDs
for 5 psi Piping Systems

Dimensions

Model	Pipe Size	Vent Connection	Swing Radius	Dimensions		
				A	B	C
325-3L47	3/8", 1/2"	325-3L: 1/8" OPD47: Integral	3" (76 mm)	3.5" (89 mm)	8" (203 mm)	3.9" (99 mm)
325-3L48	1/2"	325-3L: 1/8" OPD48: 1/8"	3" (76 mm)	3.5" (89 mm)	8.5" (216 mm)	3.9" (99 mm)
325-5L48	1/2", 3/4"	325-5L: 3/8" OPD48: 1/8"	4.4" (112 mm)	5.3" (135 mm)	10" (254 mm)	5.4" (137 mm)
325-5L600	3/4", 1"	325-5L: 3/8" OPD600: 1/8"	4.4" (112 mm)	5.5" (140 mm)	11" (279 mm)	5.4" (137 mm)
325-7AL210D	1 1/4", 1 1/2"	325-7AL: 1/2" OPD210D: 3/8"	6.75" (171 mm)	7" (178 mm)	15.4" (391 mm)	9" (229 mm)
325-9L210E	1 1/2", 2"	325-9L: 1/2" OPD210E: 1/2"	8.3" (211 mm)	9.4" (239 mm)	20.6" (523 mm)	9.1" (231 mm)
325-11L210G	2", 2 1/2", 3"	325-11L: 3/4" OPD210E: 3/4"	11.9" (302 mm)	16.5" (419 mm)	29" (737 mm)	13.5" (343 mm)

NOTE: Dimensions are maximums and to be used only as an aid in designing clearance for the valve.
Actual production dimensions may vary somewhat from those shown.

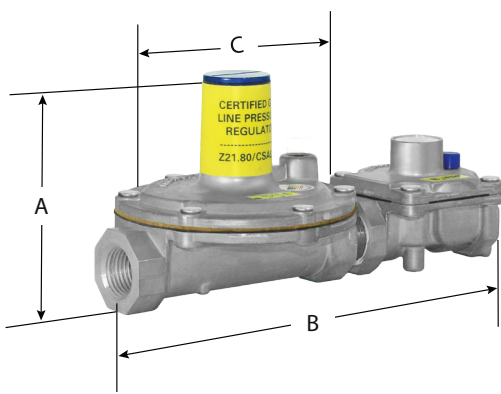

325-3L47

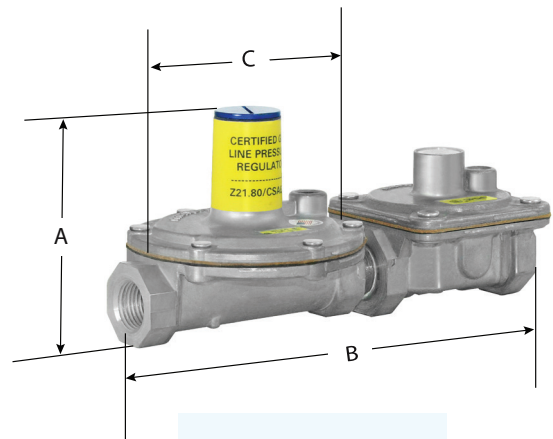

325-3L48

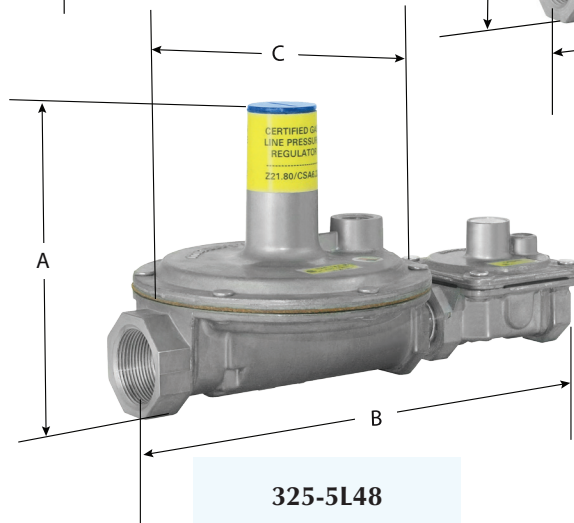

325-5L48

LINE REGULATORS

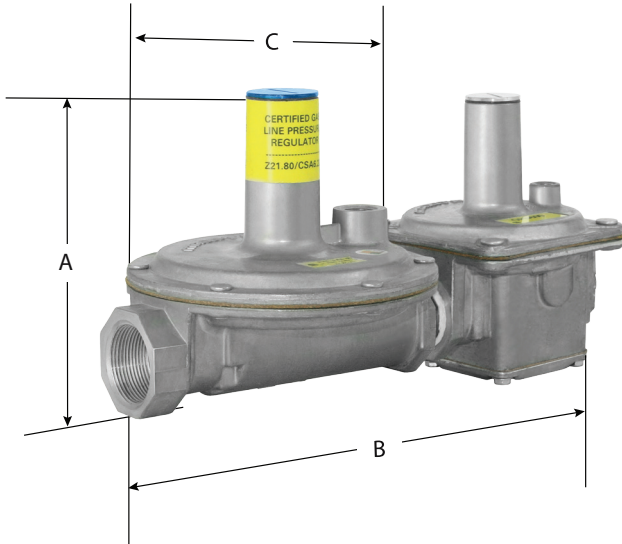

325-5L600

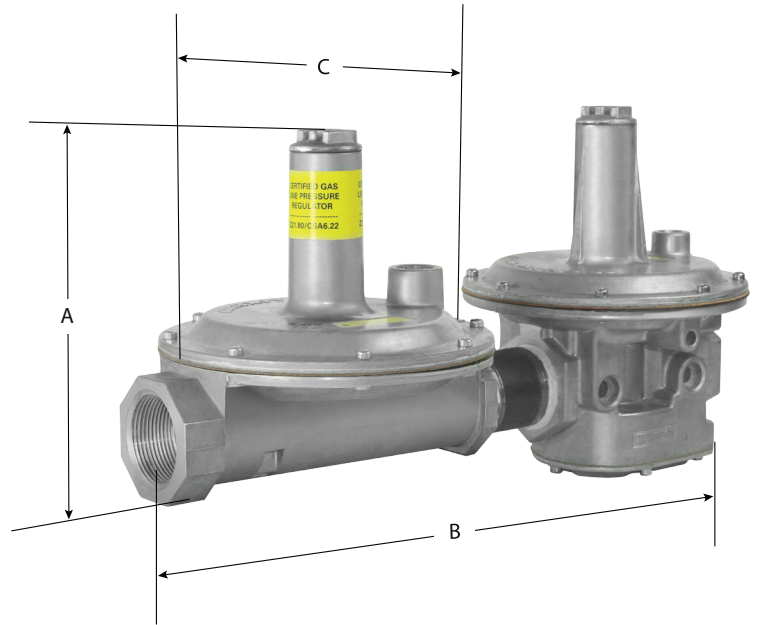

325-7AL210D

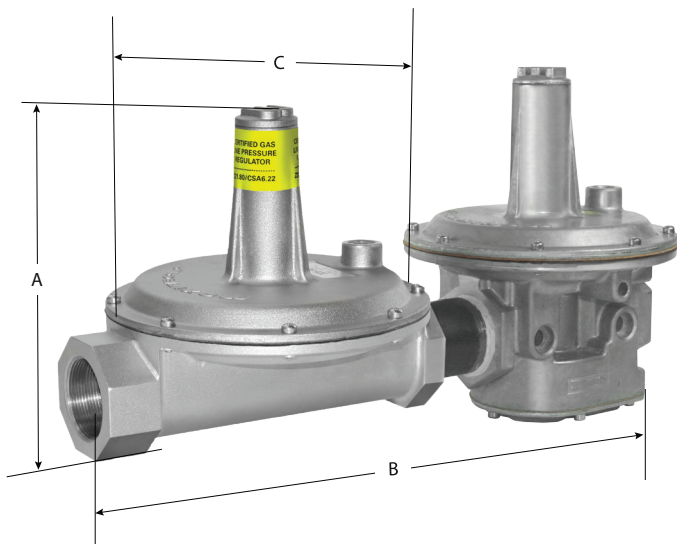

325-9L210E

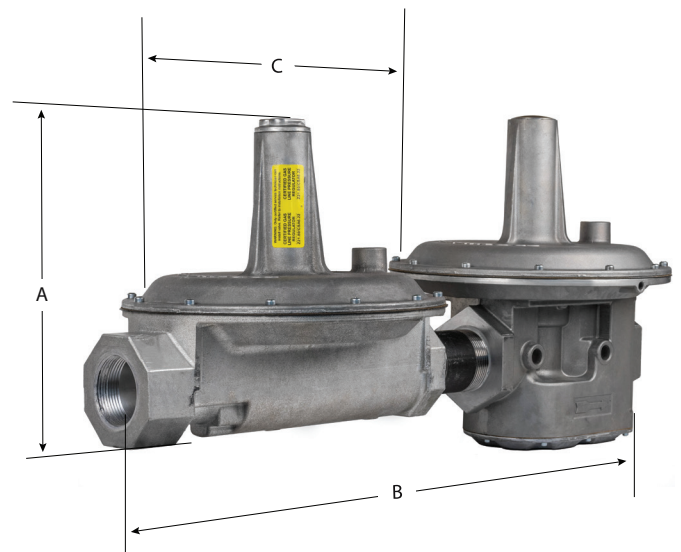

325-11L210G

SIZING A REGULATOR

See www.maxitrol.com for our Regulator Sizing Program. Please contact Maxitrol directly for more information on sizing a regulator.

System Requirements

When sizing a regulator the following must be known:

- Gas Type
- Available Inlet Pressure
- Desired Outlet Pressure
- Zero Governor Application (indicated by model number ending in "Z")
- Will the regulator control main burner and pilot load OR main burner only?
- Required minimum and maximum flow rate in cfh or m³/h or Btu/h
- Pipe Size

In most cases, the manifold pipe size has already been selected on the basis of good engineering practice, and the regulator pipe size should conform to this size.

The capacity of any regulator is not an absolute value but will vary with the application depending on the prevailing differential pressure.

▲ WARNING

Service and installation must be performed by a trained/experienced service technician.

All products used with combustible gas must be installed and used strictly in accordance with the instructions of the Original Equipment Manufacturer (OEM) and with all applicable government codes and regulations, e.g. plumbing, mechanical, and electrical codes and practices. These instructions do NOT supersede OEM's installation or operating instructions.

All Maxitrol products should be installed and operated in accordance with Maxitrol Safety Warning Instructions.

HOW TO CALCULATE PRESSURE DROP AT VARIOUS FLOW RATES FROM CAPACITY CHART

LP Applications - When using natural gas pressure drop chart to determine LP pressure drop in terms of Btu/h, multiply NAT Btu/h by 1.61; in terms of CFH multiply NAT CFH by 0.645.

$$\text{Formula: } P_2 = P_1 \times (Q_2/Q_1)^2$$

P₂ = Pressure drop at desired flow rate

P₁ = Known pressure drop

Q₂ = Desired flow rate

Q₁ = Known flow rate

A. Check Capacity Chart, insuring regulator has ample range of regulation and individual load capacities (for use with pilot) for the application.

B. Know the minimum encountered inlet pressure. MINIMUM INLET PRESSURE MINUS "P₂" MUST BE GREATER THAN DESIRED OUTLET PRESSURE. Solve for "P₂" using the formula above. (See examples on page 59.)

Sizing Examples

RUBBER SEAT POPPETS

For main burner and pilot load applications.

Example: To select an RV type regulator:

- Known: Single 150,000 Btu/h main burner; pipe size 1/2"; inlet pressure 7" w.c.; outlet pressure 4" w.c.
- Solution: The RV48 (1/2") has a maximum capacity of 230,000 Btu/h and a maximum individual load of 160,000 Btu/h. The pressure drop at a flow rate of 150,000 Btu/h is 0.4" w.c., well below the available differential of 3" w.c. The RV48 (without "L" fixed orifice) is the correct regulator to use for the application.

STRAIGHT-THRU-FLOW (S-T-F)

For main burner only applications not requiring a lockup type regulator. When sizing the S-T-F series, it is recommended that pressure drop not exceed 1/2 of available differential pressure.

Example: To select an RV type regulator:

- Known: Flow rate 2,000,000 Btu/h; pipe size 1 1/4"; inlet pressure 9" w.c.; outlet pressure 5" w.c.
- Solution: The RV81(1 1/4") has a maximum capacity of 2,500,000 Btu/h. The pressure drop at a flow of 2,000,000 Btu/h is 0.66" w.c. The RV81 (1 1/4") is the correct regulator to use with this application. The pressure drop of the RV61 (1 1/4") at a flow rate of 2,000,000 Btu/h is 2.64" w.c. This is within the available differential but exceeds the recommended 50% maximum.

LEVER ACTING

For main burner and pilot load application requiring positive dead-end lockup (see Definitions page 63).

Example: To select a 325 series regulator:

- Known: Single 145,000 Btu/h burner; pipe size 1/2"; inlet pressure 2 psi; outlet pressure 7" w.c.
- Solution: The 325-3's pressure drop at a flow rate of 145,000 Btu/h is 7" w.c., well below the available differential of 1 3/4 psi. However, the Maximum Individual Load for the 325-3 is only 100,000 Btu/h. The 325-5 (1/2") is the correct regulator to use with this application.

BALANCED VALVE

For main burner and pilot load application requiring a lockup type regulator or zero governor usage (see Definitions page 63).

Example: To select a 210 or R/RS series regulator:

- Known: Desired flow rate 6,000,000 Btu/h; pipe size 1 1/2"; inlet pressure 1 psi; outlet pressure 9" w.c.
- Solution: The 210E (1 1/2") has a maximum capacity of 10,000,000 Btu/h. The 210D (1 1/2") has a capacity of 6,000,000 Btu/h. Therefore, the 210E (1 1/2") will give you the desired outlet pressure of 9" w.c. and is the correct regulator to use for the application.

MAXITROL®

Exclusive Distributor North America
for Mertik Maxitrol

Maxitrol Company, Inc.
23555 Telegraph Rd., PO Box 2230
Southfield, MI 48037-2230
USA
Tel: +1 248-356-1400
Fax: +1 248-356-0829
www.maxitrol.com

