

ZEO

Zero Emission Odorization

Zero methane emission,
compact design

Achieving Natural Gas Odorization with Zero Methane Emission

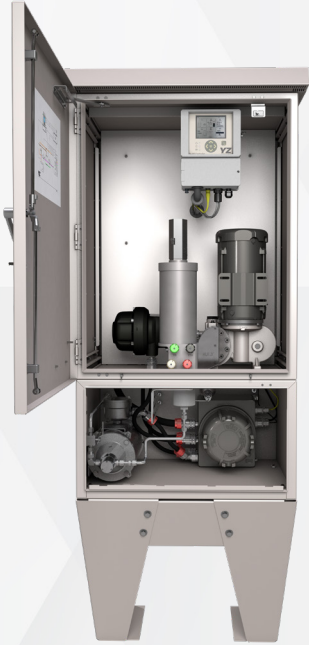

Zero Emission Odorization (ZEO)

Gas odorization is a critical safety requirement to ensure communities have a safe supply of natural gas. 30 years ago YZ Systems changed the industry by introducing the NJEX family of odorant injection systems. They have earned a reputation of delivering accurate, reliable and odor-free operation in a wide variety of mission critical applications. YZ has yet again revolutionized natural gas odorization with their latest innovation.

The new ZEO is the next generation of odorization systems. The zero-emission design consolidates the NJEX design, incorporates the proven mROY electric pump and is controlled by the new N400 controller. It delivers the same advantages as previous YZ odorization systems in a simple compact design, while producing no methane during normal operation.

Key Advantages:

- Zero emission design
- Odor free operation
- Extended design life
- Consolidated design resulting in a standard, compact unit
- Simplification in maintenance and operation

Versatile Design to Optimize Any Application & Process

Best-fit. The ZEO is a "total systems approach" designed to be an incredibly versatile system for low, mid, and high flow rates. This makes it ideal for scalability.

Process Control. The consolidated design simplifies operation and maintenance. Standard features include a double diaphragm pump, known volume Verometer, and the N400 controller to limit process disruptions.

Verification. With real-time system monitoring, documentation and a paperless audit trail, the new N400 controller provides enhanced diagnostics and troubleshooting features.

Customer Service. The ZEO is covered by YZ Technical Service, which is a dedicated global team of experienced engineers and field service technicians available 24 hours a day.

Accessories / Mechanical Systems

New N400 Controller

The ZEO works with a new YZ controller to better serve your application requirements. This model includes:

- IS-approved for C1D1 and ATEX/IECEX Zone 1 applications
- 4.4" front lit LCD display
- Memory module for audit trail
- Multi-language support
- Proportional to flow, proportional to time and batch mode options
- Modbus RTU (RS-485)
- Maintenance function wizard



mROY Pump and Manifold

The mROY metering pump with Actuator Capacity Control (ACC) is a controlled-volume, hydraulically-actuated diaphragm pump. Its compact design contains a plunger that reciprocates at a fixed rate, displacing a variable volume of hydraulic fluid and thereby actuating a flexible, chemically inert PTFE diaphragm to create the pumping action. This field-proven design enables metering with repetitive steady-state accuracy at a $\pm 1\%$ range.

The mROY delivers maximum uptime, the highest levels of accuracy, reliability and performance. With a unique redundant diaphragm feature, it protects against disruptions in the odorization process.



Key Features:

- High performance diaphragm with 96,000 hours of design life
- Double diaphragm design feature is standard to protect against process disruption
- Custom pump head uses the same proven YZ check valves NJEX has been using for 20+ years
- Compact pump/manifold design reduces potential leak paths
- Color coded valves make operation and maintenance simple
- Meets standards for CE, ATEX, and API 675



ZEO Fluid Flow Diagram

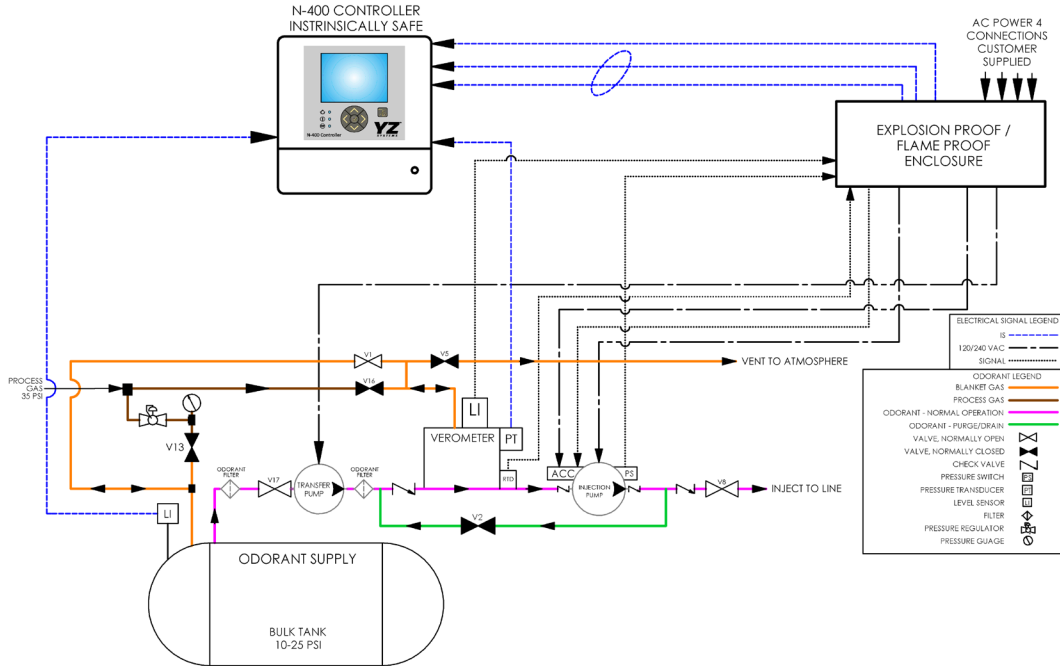

Performance at Max Pressure

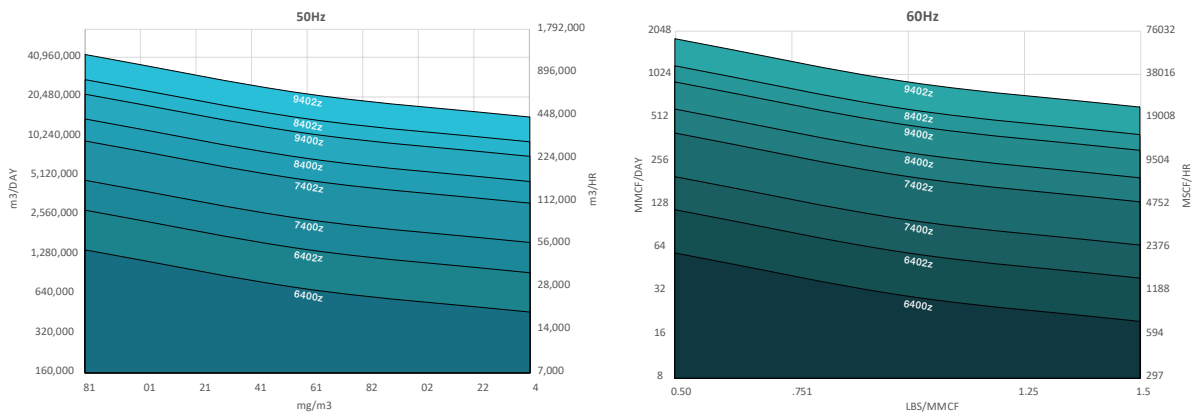

NJEX ZEO 7400Z - 00 S N - D 6 A

NJEX ZEO Gas Odorization Series

- 6400Z - Single Unit, Low Volume Primary Odorizer
- 6402Z - Dual Unit, Low Volume Primary Odorizer
- 7400Z - Single Unit, Low-Mid Volume Primary Odorizer
- 7402Z - Dual Unit, Low-Mid Volume Primary Odorizer
- 8400Z - Single Unit, Mid-High Volume Primary Odorizer
- 8402Z - Dual Unit, Mid-High Volume Primary Odorizer
- 9400Z - Single Unit, High Volume Primary Odorizer
- 9402Z - Dual Unit, High Volume Primary Odorizer

Odorant Tank Selection

- 00 - No Selection
- 01 - 20 Gallon
- 02 - 60 Gallon
- 03 - 120 Gallon
- 04 - 250 Gallon
- 05 - 500 Gallon
- 06 - 1000 Gallon
- 07 - 2000 Gallon

Enclosure Option

- A - Standard Enclosure - Angled Legs (retrofit or skid mounted)
- B - Standard Enclosure - Straight Legs

Power Option

- 6 - 60Hz, Single Phase 110/220VAC
- 5 - 50Hz, Single Phase 220VAC

Hazardous Location

- D - UL/CSA Class 1 Div. 1
- Z - UL/CSA/ATEX/IECEX Class I Zone 1

Skid Selection

- N - No Selection
- R - Rail Skid
- C - Containment Skid Selection (110% of Tank Capacity)

Relief Valve Packaging

- S - Standard
- F - Fire Size Rated

Focusing on Your Priorities

YZ Systems is committed to the safety of people and the environment and has provided precision equipment to the energy industry for the past 60 years. Our innovative designs deliver accuracy while our versatile solutions accommodate a wide range of performance requirements. Commitment to quality is our top priority to ensure the protection of your most precious assets.



YZ Systems is part of Ingersoll Rand. Ingersoll Rand (NYSE:IR) advances the quality of life by creating comfortable, sustainable and efficient environments. Our people and our family of brands work together to enhance the quality and comfort of air in homes and buildings; transport and protect food and perishables; and increase industrial productivity and efficiency. We are committed to a world of sustainable progress and enduring results.

Contact Your Rep

Visit yzsystems.com and select "Find a Sales Rep" for your local contact. For 24 hour technical support, contact (800) 653-9435.

Global Locations

Americas

8825 N. Sam Houston Parkway W.
Houston, TX 77064
T: 281-362-6500 | F: 281-362-6513
E: techsupport@yzhq.com
sales@yzhq.com

201 Ivyland Road
Ivyland, PA 18974
T: (215) 441-0800 | F: (215) 441-8620
E: techsupport@yzhq.com
sales@yzhq.com

Europe, Middle East and Africa

Pont-Saint-Pierre
10 Grande Rue
27360 Pont-Saint-Pierre, France
T: +33-(0) 2-32-68-3000
F: +33-(0) 2-32-68-3093
E: sales@yzhq.com

Middle East FZE
Jafza Lob 16 Office No. 16614
PO Box No 262384
Jebel Ali, Dubai - United Arab Emirates
T: +9714 887546 | F: +9714 88 75647
E: sales@yzhq.com

Asia

510 Thomson Road #13-01
SLF Building Singapore 298135
T: (65) 6568-2800 | F: (65) 6259-9897
E: mrapsing@miltonroy.co.sg

www.yzsystems.com