

FPCV-TO Valve Series

Full Port Control Valve



The Becker* monitor regulator from GE provides over pressure protection with guaranteed Class VI shutoff with double-seated design. The RPSR actuator and VRP-SB-PID provide excellent reliability in high profile installations.



Description

The Becker FPCV-TO Full port control valve from GE is a trunnion-mounted rotary control valve designed for monitoring or mild-duty service above ground and heavy duty service below ground. The FPCV-TO valve features a rugged design that provides maximum capacity with minimal full-open pressure drop. The FPCV-TO valve features a side entrance, forged body, and end closures, allowing for easy maintenance or repair of the control valve. The FPCV-TO valve is available in a variety of configurations ranging from 2-inch (50 mm) to 42-inch (1050 mm) bore.

Features

- High turndown capability up to 100:1
- High pressure drop shutoff capability to Class VI
- Pig-able design
- Double block and bleed design
- Bi-directional sealing on seat (Piston Effect Principle)
- Upstream and downstream seats
- Bi-directional flow capability
- Self cleaning design (when installed using left hand mount)
- Emergency sealant system
- Easy maintenance and repair
- Wide array of configurations
- Equalized break torque and running torque
- Rugged design engineered for pipeline applications
- Size Range: 2-inch (50 mm) - 42-inch (1050 mm) bore

High Turndown Capability

The number of regular runs is decreased, compared to globe pattern valves, thanks to the FPCV-TO valve's high turndown capability. The modified equal percentage characteristic of the FPCV-TO valve provides high flow capacity combined with low volume control ability. The FPCV-TO valve can exhibit a turndown ratio up to 100:1.

High Pressure Drop Shutoff Capability Class VI

The rugged design of the FPCV-TO valve allows for 100 percent psig full ANSI rated pressure drop across the control valve at shutoff.

Minimal Pressure Drop

The full port design of the FPCV-TO valve features high flow capacities that provide minimal pressure drop when the control valve is at full-open position.

Pig-able Design

Pipeline pigs can be passed easily because of the full port, full opening design of the FPCV-TO valve.

FPCV-TO Series Full Port Control Valve	
Classification	Control valve
Valve Type	Rotary trunnion-mounted ball
Applications	Monitoring or mild service when installed above ground Severe service when installed below ground
Noise Attenuation	None
Maximum Turndown	100:1
Shutoff Class	VI
Flow Characteristic	Modified equal percentage (high gain)
Product Range	
Size Range	2-inch (50 mm) - 42-inch (1050 mm) bore
Pressure Ratings	ANSI Class 150-1500
End Connection	RFFEE (standard), Weld-End, RTJ
Compatible Actuators	RPDA series actuators RPSR series actuators SYDA series actuators SYSR series actuators

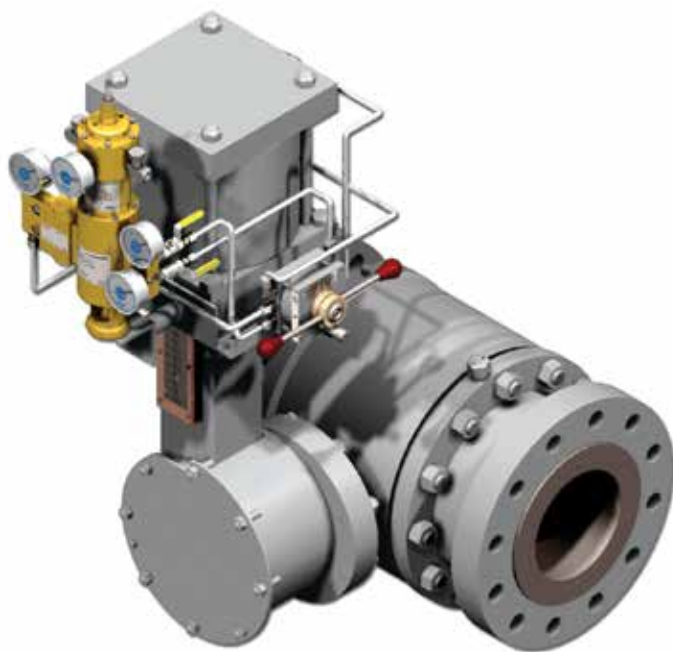

Double Block and Bleed

The FPCV-TO valve's double block and bleed feature allows for confirmation of valve seat integrity in one easy procedure. The FPCV-TO valve is equipped with a vent plug on the bottom of each control valve body. When the control valve is in a closed position, the vent may be opened to permit venting and subsequent draining of the valve body without blowing down the pipeline.

Bi-directional Sealing on Seat (Piston Effect Principle)

By providing increased seat sealing capability, the exclusive design of FPCV-TO valve seats helps ensure flow shutoff even if one of the seats is damaged. This feature is exclusive to Becker control valve products from GE. The unique "piston effect principle" causes the control valve seats to seal regardless of relative pressure differential. Hence the FPCV-TO valve may seal from either the downstream or upstream side of the control valve.

Bi-directional Flow Capability

The versatile and rugged design of the FPCV-TO valve allows for bi-directional flow across the control valve. Note that pressure drop capabilities across the valve are not affected by bi-directional flow.

Equalized Break Torque and Running Torque

Extremely accurate control of the process variables, even on the largest bore control valves, is possible because the ball element of the FPCV-TO valve is specially coated and polished, and a special seat spring arrangement is implemented. This helps ensure smooth operation with equalized break torque and running torque.

Easy Maintenance and Repair

Adding to its efficiency and economy, the FPCV-TO valve features side-entry, forged body, and end closures allowing for easy maintenance or repair of the control valve. Unlike welded-body construction valves, the FPCV-TO valve may be easily repaired and returned to service.

Clean Sweep Feature

When installed with a control valve stem in horizontal orientation, the FPCV-TO valve has the capability of preventing debris from scouring the face of the ball element or the control valve seats. This "clean sweep" capability allows debris to pass through a slight opening of the control valve.

Wide Array of Configurations

The FPCV-TO valve features one of the widest arrays of rotary control valve configurations in the natural gas industry. FPCV-TO valves are available in ANSI ratings from 150-1500, bore sizes from 2 inches (50 mm) to 42 inches (1050 mm), and a full complement of end connections and trim materials to suit many applications.

Stem Construction

The FPCV-TO valve uses dual O-ring stem seals that can be serviced while the control valve is under pressure. Additionally, the dual O-ring design can be utilized with confidence in below ground applications, unlike the gland type stem seal design.

Rugged Design Engineered for Pipeline Applications

Providing continuous service with minimal maintenance for many years, the FPCV-TO valve is designed for use in rugged pipeline applications.

Model FPCV-TO Valve Full Port Control Valve Provides Versatile Regulation at an Economical Price

Figure 3 - Model FPCV-TO valve cutaway view

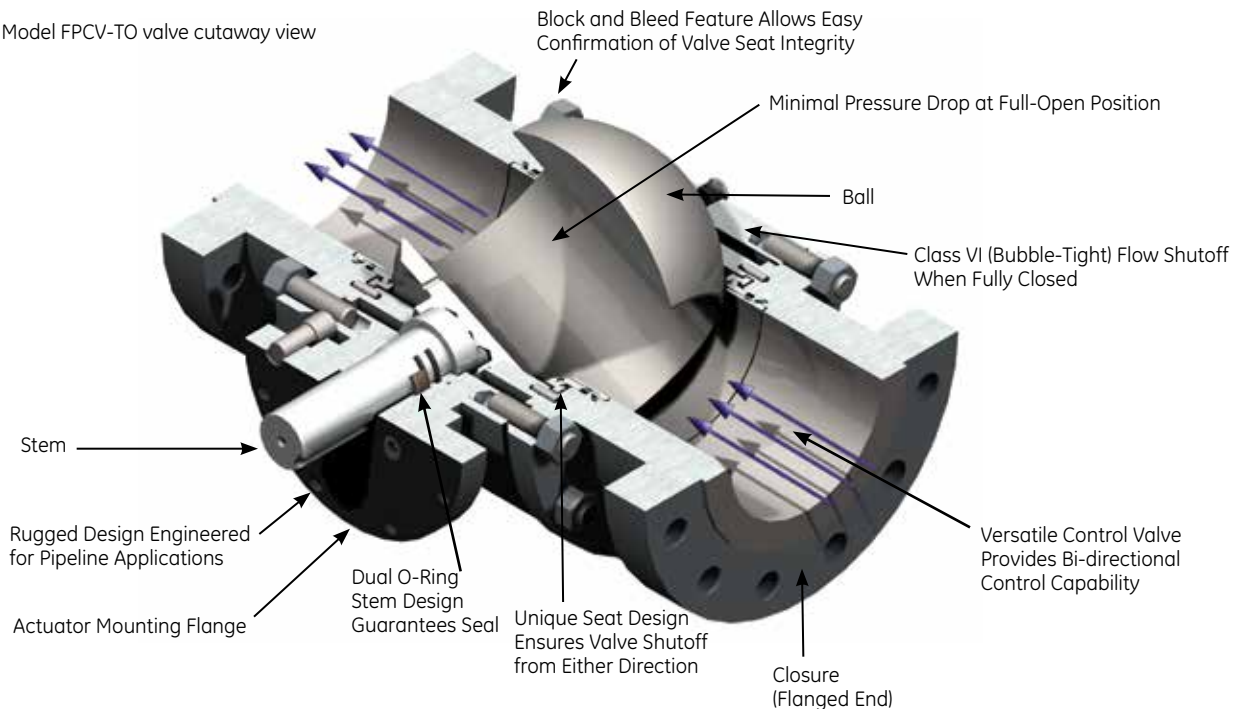

FPCV-TO valve Full Port Control Valve Features:

- Maximum noise attenuation 0 dBA above ground
- Maximum turndown ratio 100:1

Becker FPCV-TO Full Port Control Valve Components

Figure 4 - Model FPCV-TO Valve Exploded View

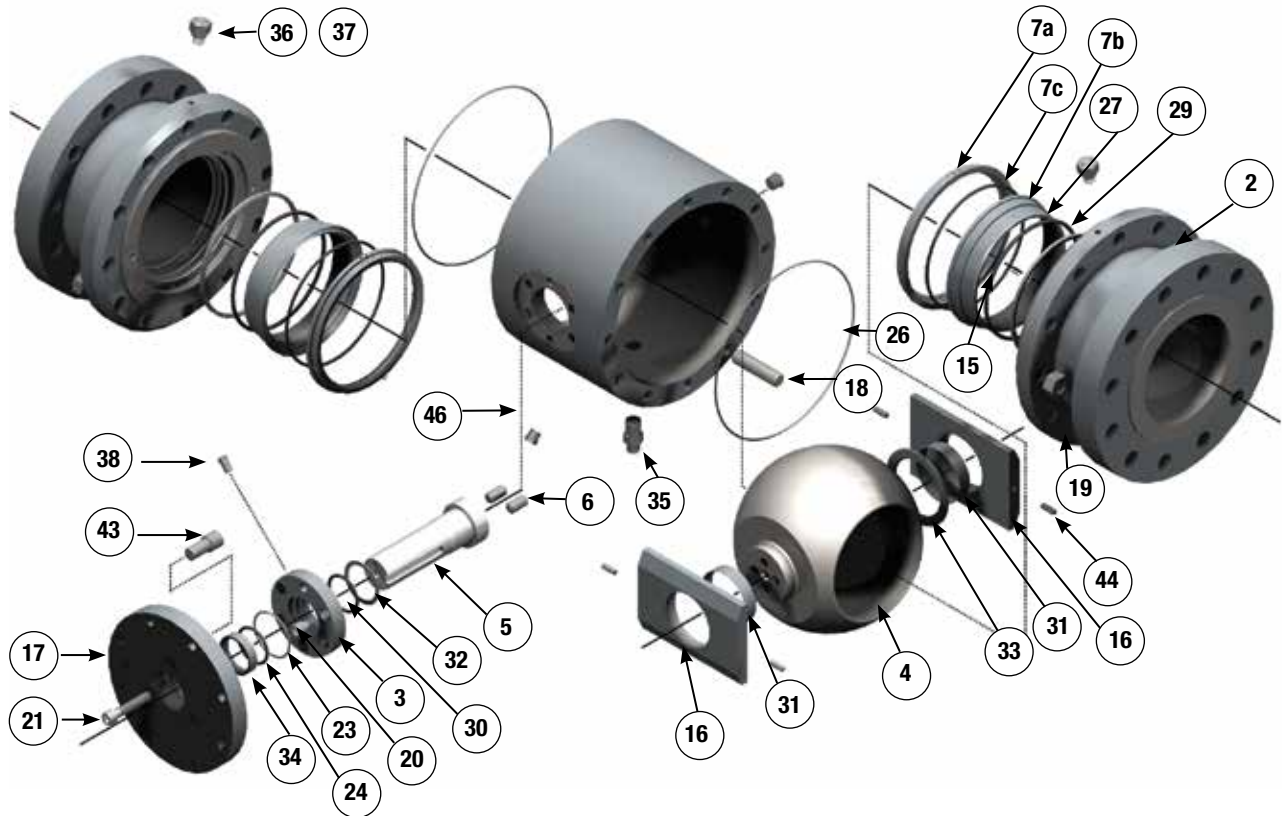

Table 1 - Model FPCV-TO Valve Materials of Construction

Item	Description	Material	Item	Description	Material
1	Body	ASTM A350 LF2, A106	24	O-Ring, Gland Plate	Viton
2	Closure (RFFE)	ASTM A350 LF2, A106	26	O-Ring, Body	Viton
3	Gland Plate	ASTM A36	27	O-Ring, Gasket, Seat	Viton
4	Ball1	ASTM A395	28	O-Ring, Seat Seal	Viton
5	Stem	AISI 1018, 4140	29	Seat U-Cup	Viton
6	Stem Pin	AISI 4140	30	Gland Plate Gasket	Vellumoid
7a	Seat Ring, Inner	ASTM A36	31	Bearing	Teflon/Steel
7b	Seat Ring, Outer	ASTM A36	32	Thrust Washer, Upper	Filled Phenolic
7c	Lock Ring	T-304 SS	33	Thrust Washer, Lower	Filled Phenolic
7d	Pin, Seat Lock Ring	SS 300 Series	34	Gland Bushing	AISI 1015
15	Seat Spring ²	Alloy X-750	35	Drain Fitting ⁵	AISI 1018
16	Bearing Retainer	ASTM A36	36	Check Fitting	AISI 1018
17	Adapter Plate	ASTM A36	37	Grease Fitting	AISI 1018
18	Body Stud	ASTM A193 B7M	38	Stem Vent Assembly	AISI 1018
19	Body Nut	ASTM A194 2HM	43	Anchor Pin	AISI 1018
20	Capscrew, Gland Plate	ASTM A574M	44	Pin, Bearing Retainer	AISI 4140
21	Capscrew, Adapter Plate	ASTM A574M	45	Hex Plug	AISI 1018
23	O-Ring, Stem ³	Viton	46	Body Relief	AISI 1018

How it Works (Downstream Pressure Control)

The energy to operate the control valve is obtained from the differential between supply gas pressure and discharge gas pressure. When the measured variable is at setpoint the pilot output pressures to cylinder top and bottom are equal (Figure 5.1). The control valve remains stationary. As the measured variable rises above setpoint, the pilot pistons move downward. This causes a decrease in cylinder top pressure creating a force to close the valve and lessen the flow (Figure 5.2). The measured variable returns to setpoint, and the pilot output pressures will automatically return to equilibrium at the new valve position. If the measured variable falls below setpoint, the opposite reaction occurs (Figure 5.3).

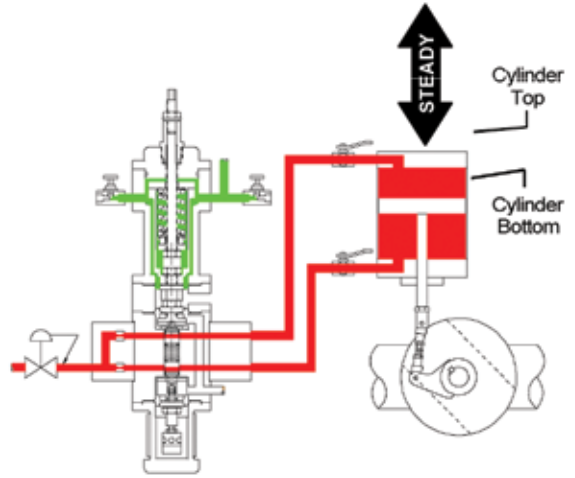

Figure 5.1 - Setpoint satisfied

When the measured variable is at setpoint the pilot output pressures to cylinder top and bottom are equal and the control valve remains stationary.

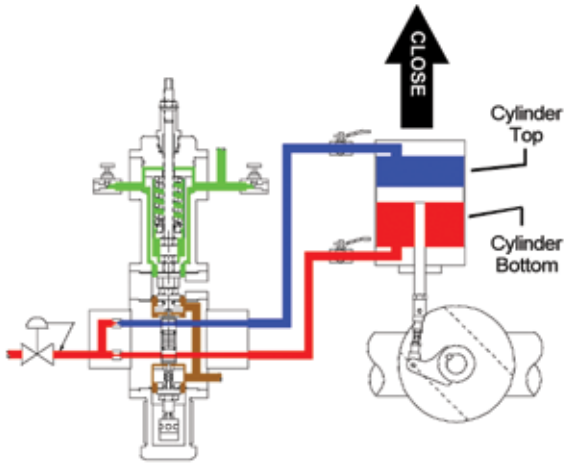

Figure 5.2 - Downstream pressure climbs above setpoint

When the measured variable rises above setpoint the pilot pistons move downward causing a decrease in cylinder top pressure. The control valve moves toward the closed position.

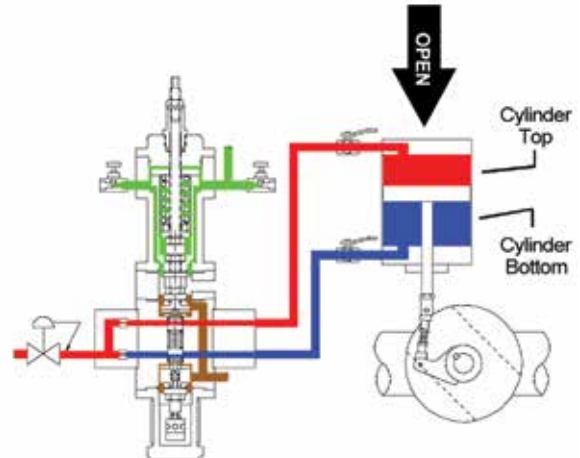

Figure 5.3 - Downstream pressure falls below setpoint

When the measured variable falls below setpoint the pilot pistons move upward causing a decrease in cylinder bottom pressure. The control valve moves toward the open position.

Schematic Legend

- Atmospheric Pressure
- High Pressure Gas
- Cylinder Loading pressure
- Measured Variable (Downstream Pressure)

Table 3 - Technical Specifications for VRP-B-CH Pilot

Technical Specifications	
Steady State Gas Consumption	~100 (see Table 4)
Supply Gas	Dry, filtered (100µ) gas
Maximum Flow Capacity	500 scfh (14.2 scmh)
Maximum Supply Pressure	400 psig (2758 kPa)
Maximum Supply-Discharge Differential	250 psig (1723 kPa)
Minimum Supply-Discharge Differential	50 psig (345 kPa)
Operative Ambient Temperature Range	-20°F to +160°F (-29°C to +71°C)
Approximate Weight	12 lbs (5.4 kg)
Control Accuracy	±0.75% of setpoint
Maximum Sensing Pressure VRP-175-CH VRP-600-CH VRP-1000-CH	225 psig (1551 kPa) 600 psig (4136 kPa) 1500 psig (10342 kPa)
Setpoint Range	3.0 psig - 1300 psig (21 kPa - 8966 kPa)
Housing	Meets NEMA 3 Classification
Installation Orientation	Vertical position recommended. Custom bracket supplied with Becker actuators from GE. 2-inch pipe mount provided for retrofit to other manufacturers' actuators.
Materials of Construction	
External Parts	Anodized AL 2024 316 SS available (for marine environments)
Internal Parts	316 SS and anodized AL 2024
Springs	Plated steel
Diaphragms	Buna-n reinforced by nylon fabric
Seats and O-rings	Buna-n
Tubing and Tubing Fittings	316 SS
Gauges	2 1/2-inch dial liquid filled with stainless steel case (standard issue with units of psig dual units of psig/kPa available)

Table 4 - Bleed Rates (consumption) for Becker Control Instrumentation
Becker control instrumentation from GE features low bleed and ZERO bleed technologies to reduce fugitive natural gas emissions and any environmental impact.

	VRP-CH Pilot	VRP-B-CH Pilot	VRP-SB-CH Pilot	VRP-SB-GAP Pilot	VRP-SB-PID Pilot	HPP-4 Positioner	HPP-5 Positioner	HPP-SB Positioner	DNGP Positioner
Bleed Rates (Consumption)									
Steady State Bleed ³ Non-Bleed	~100	<10	zero	zero	zero	~100	<10	zero	zero
Full-Open/ Full-Closed Bleed to Pressure	Y1	N	Y	Y	N	Y1	Y2	Y	Y
Bleed to Pressure System (BPS) ⁴	Y	N	Y	Y	N	Y	Y	Y	Y

Notes

1. Requires Model PS-2 or NBV Non-Bleed Device to eliminate bleed
2. Requires Model DPS-2 or NBV Non-Bleed Device to eliminate bleed
3. Bleed rates are estimated utilizing supply gas pressure = 100 psig
4. Bleed to Pressure System (BPS[™]) eliminates all atmospheric bleed

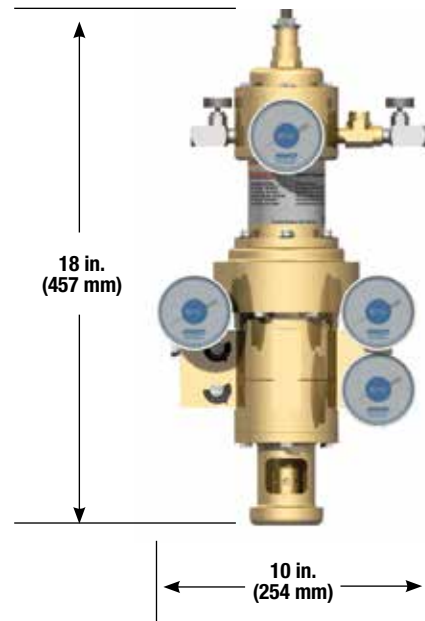

Figure 6 - Overall dimensions of VRP-600-B-CH Pilot Control System

Table 5 - Selection Chart for VRP-B-CH Series Pilots

VRP-SB-CH Model Number	Control Range (psig/kPa)	Spring Color	Part Number	Setpoint change/revolution of setpoint screw ²	Maximum Remote Setpoint Range ³	Repair Kit Number
VRP-175-CH ¹	3.0 – 10 psig (21 – 69 kPa)	Gold	25-8236	0.57 psig/rev (3.9 kPa/rev)	3.1 psig (21.4 kPa)	30-9002
	7.0 – 30 psig (48 – 207 kPa)	Beige	25-8238	2.0 psig/rev (14 kPa/rev)	11 psig (75.8 kPa)	30-9002
	15 – 50 psig (103 – 345 kPa)	Burgundy	25-8239	3.0 psig/rev (21 kPa/rev)	16.5 psig (113.8 kPa)	30-9002
	20 – 85 psig (138 – 596 kPa)	Pink	25-8240	6.4 psig/rev (44 kPa/rev)	35.2 psig (242.7 kPa)	30-9002
	50 – 175 psig (345 – 1207 kPa)	Yellow	25-1306	23 psig/rev (159 kPa/rev)	125 psig (862 kPa)	30-9002
VRP-600-CH	25 – 140 psig (172 – 965 kPa)	Beige	25-8238	7.4 psig/rev (51 kPa/rev)	41 psig (283 kPa)	30-9004
	50 – 175 psig (345 – 1207 kPa)	Burgundy	25-8239	11 psig/re (76 kPa/rev) v	62 psig (427 kPa)	30-9004
	135 – 300 psig (931 – 2069 kPa)	Pink	25-8240	24 psig/rev (166 kPa/rev)	132 psig (910 kPa)	30-9004
	275 – 600 psig (1896 – 4137 kPa)	Yellow	25-1306	85 psig/rev (586 kPa/rev)	325 psig (2241 kPa)	30-9004
VRP-1000-CH	550 – 1000 psig (3792 – 6895 kPa)	Yellow	25-1306	144 psig/rev (993 kPa/rev)	700 psig (4826 kPa)	30-9005

Notes

1. These models should only be used for applications that require high gain. Consult GE prior to specifying these models.
2. Maximum remote setpoint range is based upon Model SM-1140 remote setpoint module with maximum motor range of 5.8 revolutions. See GE for additional information.
3. Maximum remote setpoint range reported is applicable to units with discrete (pulse) signal. Remote setpoint modules with analog (4-20 mA) signal have a maximum remote setpoint range equal to the full control range of the VRP-B-CH.



Figure 7.1 - VRP-175-CH



Figure 7.2 - VRP-600_B-CH



Figure 7.3 - VRP-1000-B-CH

VRP-B-CH Series Pilot Accessories

Realize Optimum Performance of your VRP-CH Series Pilot with these popular instrumentation accessories!



NBV Series No-Bleed Valve

The NBV series no-bleed valve eliminates bleed gas from Becker double-acting control instrumentation when the corresponding control valve is at full-open and full-closed positions. This is ideal for monitor regulators and standby regulators that typically remain in the full-open or full-closed positions. The NBV series features bleed shutoff at both ends of valve travel without adjustment. This valve is the primary choice for non-bleed technology on Becker double-acting control instrumentation. It is compatible with all Becker double-acting Valve Regulator Pilots (VRP) and double-acting High Pressure Positioners (HPP).

Reference Becker NBV No-Bleed Valve sales literature from GE for additional information.



PS Series Non-Bleed Sensor

The PS series non-bleed sensor renders the Becker double-acting control instrumentation non-bleeding when the control valve reaches full-open and full-closed positions. This is ideal for monitor regulators and standby regulators that typically remain in the full-open or full-closed positions. The PS series features bleed shutoff at one end of valve travel. If bleed shutoff is required at both ends of travel, two PS sensors will be required. The PS sensor is the secondary choice for non-bleed technology and should be used only in applications where the NBV valve will not suffice, such as when the VRP-CH must discharge to high pressure systems (above 60 psig).

Reference Becker PS-2 Series sales literature from GE for additional information.



SP Series Setpoint Pump

The SP series setpoint pump provides a simple and accurate method of applying false signal pressure during initial adjustment of pilots. The pump can provide a false signal pressure of 20 percent-40 percent in excess of working pipeline pressure, which eliminates the need for nitrogen bottles or electronic calibration devices. The setpoint pilot is compatible with all models and series of Becker VRP pilots.

Reference Becker SP setpoint pump sales literature from GE for additional information.



RSM Series Remote Setpoint Module

The remote set point module provides remote adjustment of VRP-CH setpoint via an electrical input signal. All remote setpoint motors are equipped with internal limit switches to prevent over-travel of setpoint. A 4-20 mA feedback of the remote setpoint module motor is standard. All Becker RSMs from GE are rated explosion proof Class 1, Div. 1 for use in hazardous locations. The standard RSM input signals are:

Digital Pulse Input

- 24 V D.C.
- 120 V A.C.

Analog Current Input

- 4-20 mA command signal/24 V D.C.
- 4-20 mA command signal/120 V A.C.

Reference Becker RSM Remote Setpoint Module sales literature from GE for additional information.



Panel Mounting

Custom panel mounting is available to suit the specific application needs. All panels come fully assembled, tested, and adjusted per requirements. Panel mounting simplifies retrofit of Becker instrumentation from GE to existing equipment and help ensure satisfactory performance and fit. A variety of configurations and options are available.



Stainless Steel Option

All Becker Precision Control instrumentation from GE is manufactured from high-strength anodized aircraft aluminum alloy (AL2024). The standard aluminum construction provides adequate durability in most installation environments. In applications where the environment is unusually harsh, the instrumentation may be specially ordered in a stainless steel option. The stainless steel option is typically utilized in the following areas:

- Marine environments
- Chemical plants
- Offshore platforms
- Coastal regions

Table 6 - Selection table for Becker Control Valves and Actuators

	VRP-CH Pilot	VRP-B-CH Pilot	VRP-SB-CH Pilot	VRP-SB-GAP Pilot	VRP-SB-PID Pilot	HPP-4 Positioner	HPP-5 Positioner	HPP-SB Positioner	DNGP Positioner	Notes
Applications										
Pressure Control	•	•	•		•	•	•	•	•	1,2
Flow Control						•	•	•	•	2
Power Plant Type Pressure Control	•				•	•		•	•	3
Power Plant Type Flow Control						•		•	•	3
Surge Control						•		•		
On/Off				•						
Compatible Actuators										
RPDA Series (Small Models)	•	•		•		•	•		•	4
RPDA Series (Large Models)	•			•		•			•	5
RPSR Series			•	•	•			•	•	
LPDA Series (Small Models)	•	•		•		•			•	4
LPDA Series (Large Models)	•			•		•	•		•	5
LPSR Series			•	•	•			•	•	
LD Series			•	•	•			•	•	6
Instrumentation Options										
Bleed to Pressure System BPS*	•		•	•		•	•	•	•	7
AB Series Atmospheric Bleed Control	•		•	•		•	•	•	•	
NBV Series No-Bleed Valve	•	•				•	•			8
DPS-2 Series Non-Bleed Sensor	•	•				•	•			9
PS-2 Series Non-Bleed Sensor	•					•				9
SP Series Setpoint Pump	•	•	•	•	•					
RSM Series Remote Setpoint Module	•	•	•	•	•					
Panel Mounting	•	•	•	•	•				•	
Stainless Steel Option	•	•	•	•	•	•	•	•		
VB Series Volume Booster	•		•		•	•		•		10
QEV Series Quick Exhaust Valve				•				•		
I/P Transducer						•	•	•		
SLV Series Signal Lock Valve						•	•	•		

1. Pressure control applications include: pressure letdown, primary regulation, monitors, standby, overpressure protection, underpressure protection, and relief valve.
2. All positioners require controller device to perform pressure control or flow control.
3. Power plant regulation includes all power plants and "fast-acting" short systems.
4. RPDA and LPDA small models are defined as actuator sizes 14L and smaller (< 2000 in³ / 0.033m³)
5. RPDA and LPDA large models are defined as actuator sizes 12T and larger (≥ 2000 in³ / 0.033m³)
6. LD series actuators are limited to Becker CVE series globe valves
7. BPSTM is limited to discharge pressure systems below 300 psig (2068 kPa). Consult GE for application assistance.
8. NBV no-bleed valves may only be utilized when P_{discharge} ≤ 60 psig (414 kPa) and/or P_{supply} ≤ 150 psig (1034 kPa).
9. PS-2 and DPS-2 non-bleed sensors must be utilized when P_{discharge} > 60 psig (414 kPa) and/or P_{supply} > 150 psig (1034 kPa).
10. VB series volume boosters are necessary for power plant regulation, surge control applications, or when large model RPDA are utilized.



Figure 9- Model VRP-B-CH Pilot with Electrical Override

A Model VRP-175-B-CH pilot is shown here with Model NBV-70 no-bleed valve and electrical override system. The VRP-175-B-CH pilot is designed for lower pressure setpoint pressure control application. The VRP-175-B-CH pilot features simplicity and minimal bleed when in control. The addition of the NBV-70 valve provides complete elimination of atmospheric bleed gas when the control valve is at full-open or full-closed positions. The electrical override will close the control valve upon application of close electrical signal and return to pressure control upon receipt of control electrical signal.

CAUTION: This information is intended as a guideline for application of Becker Precision Equipment products. GE Becker strongly recommends consulting GE's Engineering team prior to application of any product.



GE Oil & Gas

1550 Greenleaf Avenue
Elk Grove Village, IL 60007
Visit us online at: www.geoilandgas.com

©2014 General Electric Company All Rights Reserved
*Denotes trademarks of the General Electric Company.
Other names are for informational purposes and may
be trademarks of their respective owners.